

Event Horizon

Solar Power Systems and Equipment

Call 616-795-5285

Hand or Motor Driven Water Pump



Can be added to your well!

Easily fits inside your existing well pump casing

**Highly effective for
emergency water or remote sites.
Pump by hand or use solar powered 12 volt motor**



We highly recommend this pump for either an emergency waterpump for your existing well or as a remote site water pump for wells with common 2" through 8" casings. Fresh water can be easily pumped from as deep as 300'. The hand effort required from a typical depth of 100' is only 13 pounds of child-like downward force for 3 gallons per minute. **The Model 100 pump self-primes** and can deliver water at up to 100 psi which allows your home pressure tank to be charged by hand or get water right from the spigot.

This device is extremely high-precision. Many of our customers call us after they receive it just to tell us how impressed they are with its quality. Precision built, simple installation and very affordably priced. This is the answer to your water concerns.

**This unit installs in your well along side your existing pump for emergency water.
It can also be used as a primary pump for remote sites.**

**Use your Visa or Master Card
Call 616-795-5285**



High-precision CNC machined and the pump kit includes a new well cap for your well.

Construction Features

Easily fits inside your existing well case beside your existing electric pump system. Can be used as a stand-alone pump in as little as a 2 inch well casing or as a secondary system in 4 inch or greater casings.

100 percent CNC machined in an **aerospace quality manufacturing facility in the United States** by experienced craftsmen for absolute quality control. Five year warranty on materials and workmanship.

The pump body features corrosion-resistant high-grade stainless steel construction in a **freeze-resistant design** for years of trouble-free use. Comes standard with a powerful 24" high-grade aluminum lever handle. The pump is designed to be functional for the next 50 years to assure you of ready access to your own reliable fresh water during any power emergency.

Easy to install; most owners can do it themselves with no special tools. With the schedule 80 PVC pipe and the compact pump cylinder a typical 100 foot installation is easy and can be completed in an hour by two people.

Pump Pricing

The most popular "lever handle" pump kit (Model 100L) comes complete with all necessary upper installation components: Submersible stainless steel pump cylinder, a 2", 4", 5", 6" or 8" well casing cover with clamp flanges, and the upper pump/spigot assembly for **only \$549**. A "special order" tamper resistant (Model 100LTR) is \$599.

A "T" handle version (Model 100T) is available for pumping depths up to 50 feet for **\$389**. There is also a tamper resistant "T" Handle model for \$439.

Drop Pipe

The Drop Pipe Kit includes a 1" schedule 80 PVC with coupling, delrin rod guide, and one 80,000 psi fiberglass pump rod with integral stainless steel fittings. Each drop pipe kit is sold in 9' lengths for \$29. U.P.S. limits packages to 9' in length therefore we offer the drop pipe kits in 9' lengths. Example: If an installation requires the pump to be at 60', then seven 9' kits (7 x 9 = 63') are needed, one of which is the required "top pipe" section which is slightly different than the standard sections.

Five Year Warranty:

Manufacturer's warranty includes all parts of the system for a five year period to be free of defects in materials and workmanship. They will replace any component that is defective.

Maximum flexibility. Pump by hand or attach the 12 volt motor option und use solar power - as little as a 10 watt panel for emergency water. See details that follow.



Solar Power
Use solar power for your water pump



Hand Powered or Motor Driven with solar power

Add the motor drive option and you have automatic fresh water delivery. The 12v motor can be powered by just a battery (car or marine type), or in combination with ONE solar panel or small wind generator for indefinite regular pumping, as well as 110v inverter/utility power using a 12 volt converter. The gear motor can be ordered as either 1/10 horsepower or 1/5 horsepower depending on the flow rate and the amount of motor current you desire. The 1/10 HP motor draws an average of 60 watts (5 amps at 12 volts), and the 1/5 HP motor draws 120 watts (10 amps at 12 volts) during the completed stroke cycle. The pump stroke setting is adjustable, however to optimize motor current draw and flow rate the following table lists the recommended settings.

Flow Capacities and Pressures

Maximum Total Head	Flow Rate GPM 1/10 HP / 1/5 HP	Pump Stroke Setting
240 feet (104 psi)	.75 / 1.5	2.3"
160 feet (69 psi)	1.0 / 2.0	3.5"
126 feet (54 psi)	1.4 / 2.0	4.6"
92 feet (43 psi)	1.7 / 2.0	5.8"
76 feet (33 psi)	2.0 / 2.0	6.9"

Notes on calculations:

1. 100 feet of head equals 43.4 PSI.

2. Example of total head calculation: The well water level is at 80 feet, the pump is at 100 feet and we want to deliver 30 psi from the pump head. $30 \text{ psi} = 100/43.4 \times 30 = 69$ feet of head. Total head = $80 + 69 = 149$ feet of total head. From the chart, see the next highest head of 160 feet.

The motor drive easily bolts-on the pump body in place of the handle. This arrangement can serve as a very practical water delivery method for remote cabins, livestock watering, etc. or emergency water during extended power outages. The motor drive option speeds water delivery, but can also be changed back to manual in just a few minutes, adding to the pump's versatility under any condition. An ideal, easy solution for fresh water during power emergencies or for greater independence.

12 volt Motor Option Details

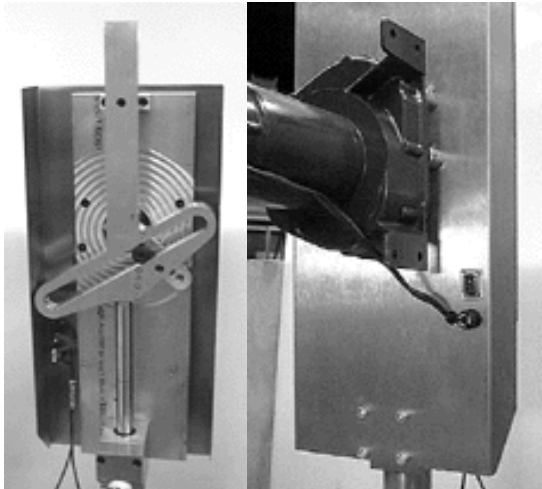

100% CNC machined in a U.S. aerospace facility.

The 12 volt motor drive option costs **\$497.00** for the 1/10 HP or **\$597.00** for the larger capacity 1/5 HP motor unit. The picture on the left with cover removed shows gear-motor cam action. The picture on the right shows an on/off switch and safety fuse. The motor housing is made of quality stainless steel and designed for rugged outdoor conditions. We can advise you on how to best utilize the motor drive for your particular situation using a 12v battery, solar power or other alternatives. Comes with a full one year warranty.

Call us for assistance and specific pricing for your situation.

Ordering Information

What information do you need to order your pump?

Specify which pump kit. Either a **100L** for 50 - 500 foot systems, or a **100T** - for up to 50 foot systems. Either of these also come in a Tamper Resistant model (100L-TR or 100T-TR) if your situation requires added security. The 100T is the same pump without the lever handle linkage and instead has a "T" handle like a bicycle pump. It is cheaper but requires effort in the upward direction as opposed to downward with the lever handle.

Specify your cover size and style. The pump price includes a cover. Just tell us what size your well case is and whether you have existing pump piping coming through your cover. Some electric pump systems bring the pressure piping below ground to your house. This is commonly referred to as a "Pitless Adapter". To measure your well case you can wrap a tape around it and divide by 3.14 to get the outside diameter. The case size is 3/8 to 5/8" less than this measurement . 2" case = 2.38 OD, 4" = 4.50 OD, 5" = 5.56 OD, 6" = 6.62 OD, 8" = 8.62 OD.

Specify the total depth you intend to pump from. Remember that 20 feet into your **static water level** is all that is normally necessary unless your recovery rate is less than the expected output from the pump you order. Your total well depth is unimportant. We can advise you on this if you have any questions.

For motorized pumping:

Specify which gear-motor. Either the 1/10 H.P or the 1/5 H.P. for added flow rate in deeper wells.

Price List

<u>Part #</u>	<u>Description</u>	<u>Price</u>
100L 100L-TR	Lever Handle hand pump and cylinder Tamper Resistant model	549.00 599.00
100T 100T-TR	T-Handle hand pump for depths of up to 50 feet Tamper Resistant model	389.00 439.00
100GM 105GM	Bolt-On 12 volt 1/10 HP gearmotor unit Bolt-On 12 volt 1/5 HP gearmotor unit for added flow rate	497.00 597.00
109DPT	9' drop pipe kit with rod and guide for top section (one required)	29.00
109DP	9' drop pipe kit with rod and guide for remaining drop pipe length - specify number of these 9' kits to achieve total depth.	29.00ea.
109R	9' fiberglass rod. (spare part- not needed with order)	15.00
100RG	Delrin Rod Guide (spare part - not needed with order)	4.00
C2	2" Well cover	included
C4	4" Well cover for pitless adapter	included
C4P	4" Well cover with 1" auxiliary pressure port	included
C5	5" Well cover for pitless adapter	included
C5P	5" Well cover with 1 1/4" auxiliary pressure port	included
C6	6" Well cover for pitless adapter	included
C6P	6" Well cover with 1 1/4" auxiliary pressure port	included
C8	8" Well cover for pitless adapter	included
C8P	8" Well cover with 1 1/4" auxiliary pressure port	included
SP	Special cover - 6-1/4" (or call for other custom sizes/features)	40.00

Typical Hand Pump Order

This order would be a complete hand pump system to fit a 6" case with an auxiliary port for the existing A.C. pump. This system will provide 63 total feet of drop pipe (7 x 9') and will pump 3+ gallons per minute.

Quan.	Part#	Description	Price
1	100L	Lever Handle Pump and Cylinder	\$549
1	C6P	6 inch well cover with auxiliary port	incl.
1	109DPT	Top 9' Drop Pipe Section	29
6	109DP	Standard 9' Drop Pipe Sections	174
TOTAL before shpg.			\$752

Shipping Information:

The pump system is shipped via United Parcel Service ground transportation unless otherwise requested. Shipping costs vary depending on the total items ordered and from state to state. A typical 100 foot hand pump order will run from \$30 to \$90 depending on the location. We provide the shipping cost amount when you order your pump.

This is a high quality pump offering an effective solution for emergency water or remote site pumping.



Simple. Effective. Reliable. Affordable.

Works with existing well-pump or as stand alone pump.

Hand Powered or Motor Driven with Solar Power.

Contact us for more information or to order yours.

Of all the things important, nothing is more important than your water.

Call 616-795-5285

Event Horizon

Solar Power Systems and Equipment

APPENDIX A
Assembly Parts List
Shows complete Hand Pump Model

Hand Pump Assembly

- P1 -Pumping Cylinder
- P2-Pump Head
- P3-Top Pump Rod
- P4-Lever Bracket
- P5-Lever Link Arm
- P6-Lever
- P7-Clevis
- P8-Pivot Pin
- P9-Well Cover
- P10- Split Flange
- P11-Safety Tool

Drop Pipe Kit(s)

- D1-Standard Drop Pipe
- D2-Sucker Rod
- D3-Sucker Rod Guide
- D5-Top Drop Pipe

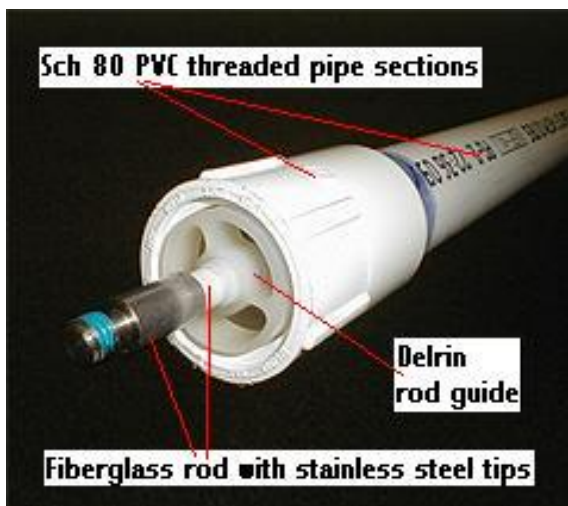
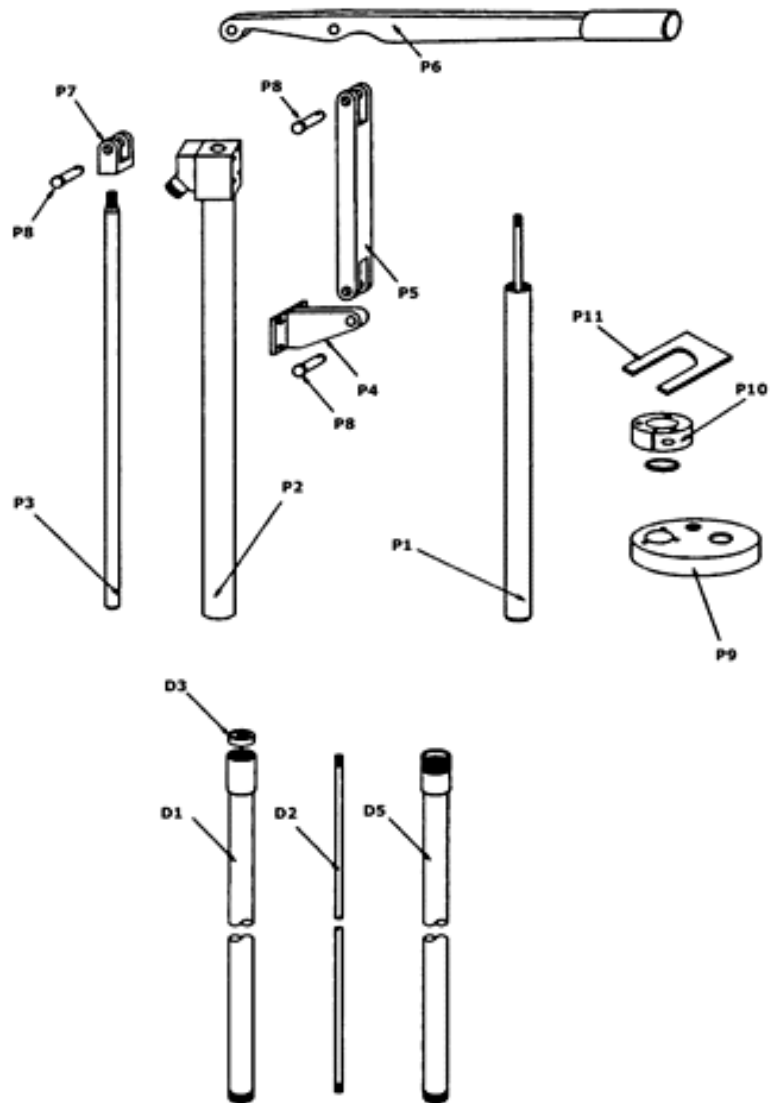

9' drop pipe sections for easy installation

APPENDIX B

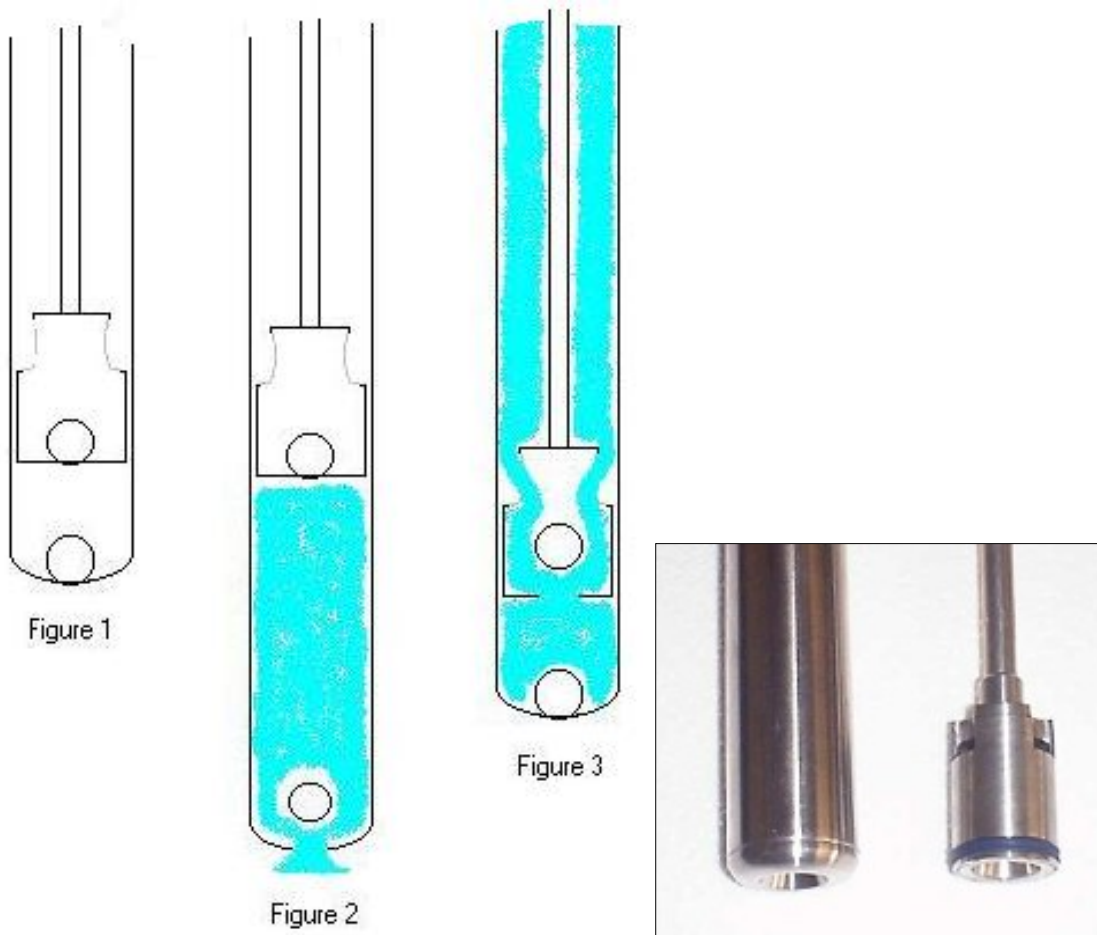

How the pump cyclinder works.

(This pop-up window is resizable to assist viewing)

Stainless steel cylinder (1" I.D.) is easily lowered into your well casing below static water level - along side of your existing submersible pump drop pipe (requires minimum 4 inch well casing if you have an existing pump).

Figure 1: Pump cylinder action at rest.

Figure 2: Upward piston action creates a vacuum and lifts lower ball, allowing water in to the pump cylinder.

Figure 3: Downward piston action closes lower ball and moves water up through the piston ports into the drop pipe.

Successive up/down stroke easily lifts water to pump spigot.

Extremely simple action with precision CNC machined stainless steel components for 50 year durability.

APPENDIX C

These are example installations for this incredibly versatile hand or motor driven water pump.

Hand pumping out of your existing water well to pressurize your home water system.

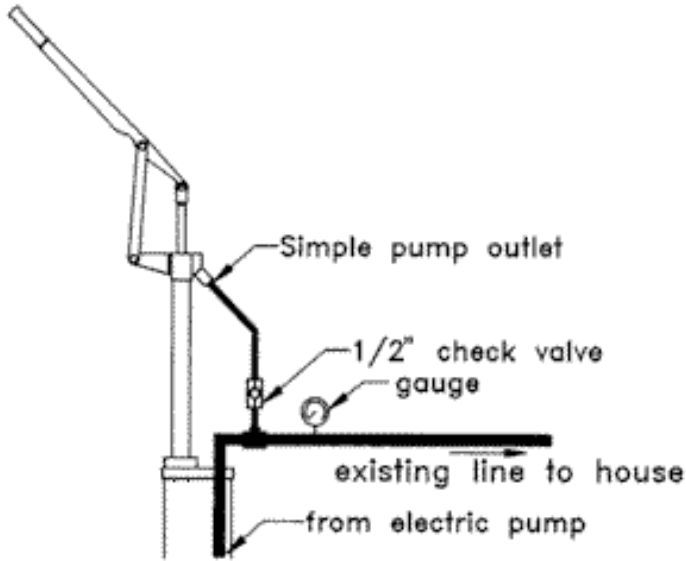

House Pressurize Diagram

An excellent emergency water supply.

This example diagram shows how the pump easily fits along-side your existing electric pump using the top casing adapter. A minimum 4 inch I.D. well casing is needed. Most residential well casings are adequate.

Your existing submersible pump is undisturbed during this easy installation. If your well has a pit-less adapter the installation is extremely easy. If you have a pressurized water line coming out of your above ground section of well casing, then you will have to support the weight of the pressurized line while installing this pump, but this is still relatively easy. We can advise you on the best method to temporarily support it during installation.

To increase the diversity, you can also receive water right at the spigot or fill a separate reservoir by adding a simple T with two shut-off valves at the pump outlet. You can fill a reservoir and then gravity feed your home or install an inexpensive 12 volt motor home pump to pressurize your entire home (see below). By installing the motor drive option the entire system is fully automatic. You can use a standard pressure tank and switch for independent operation or integrate it into your existing system so it comes on automatically when your utility power fails. We can assist you with any technical questions.

Incredibly versatile, high quality construction.

Automatic motor drive water pumping from your existing well.

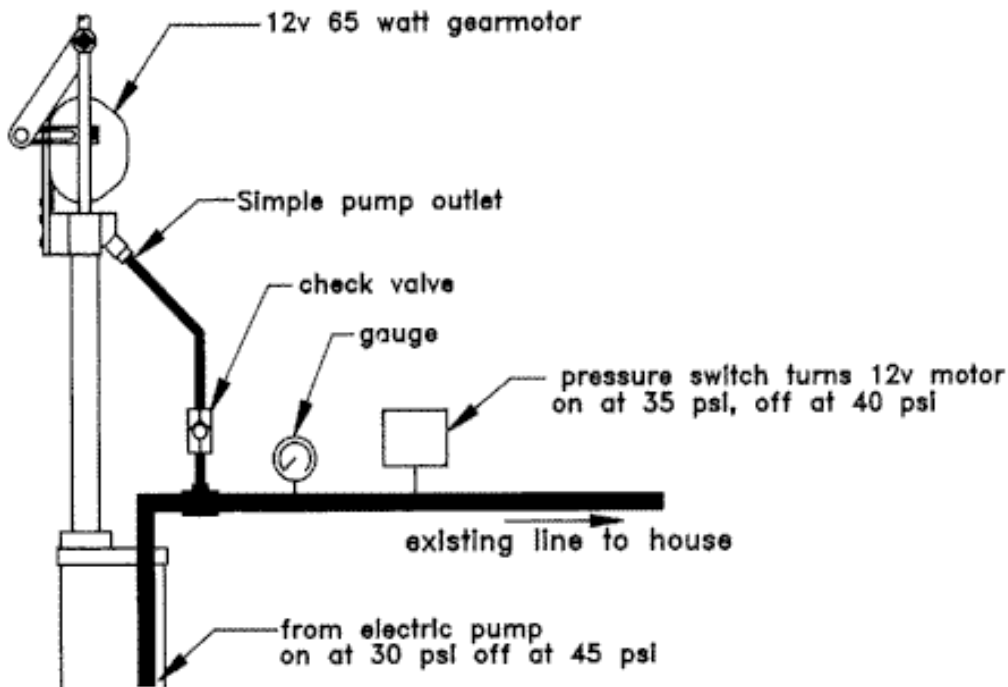

House Pressurize Diagram

APPENDIX D

For greater emergency flexibility

Add a 200 - 500+ gallon poly reservoir and either gravity feed or pressure-pump water to your home

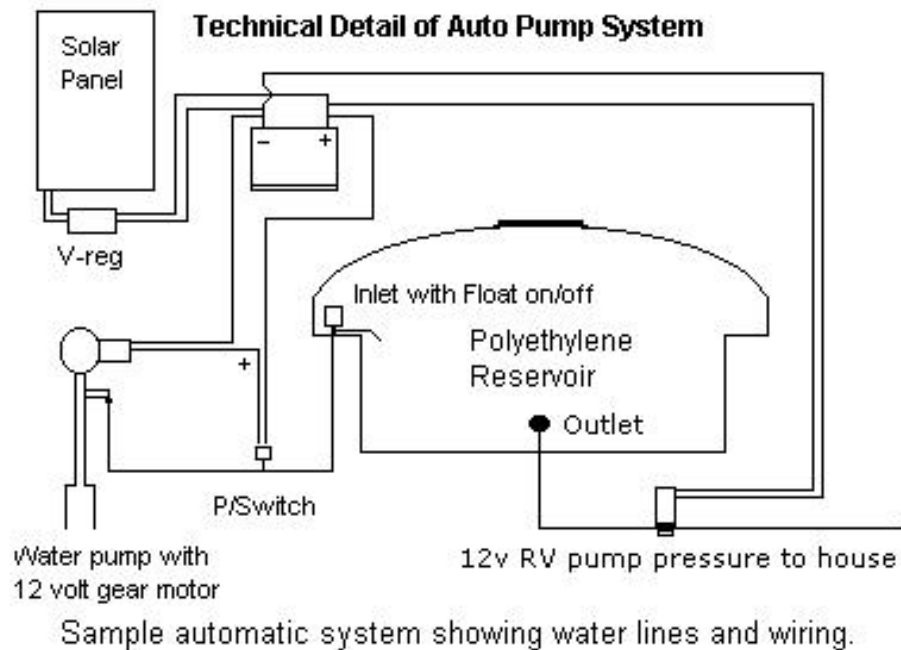

A 12v motor home pump can pressurize your entire home. Reservoir with 12v RV pump works very well with either hand or motor driven pumping. You can also substitute reservoir and float for standard pressure tank. The style of reservoir shown works best with float switches. A single solar panel or wind unit with a small battery can power the 12 volt motor drive.

APPENDIX E

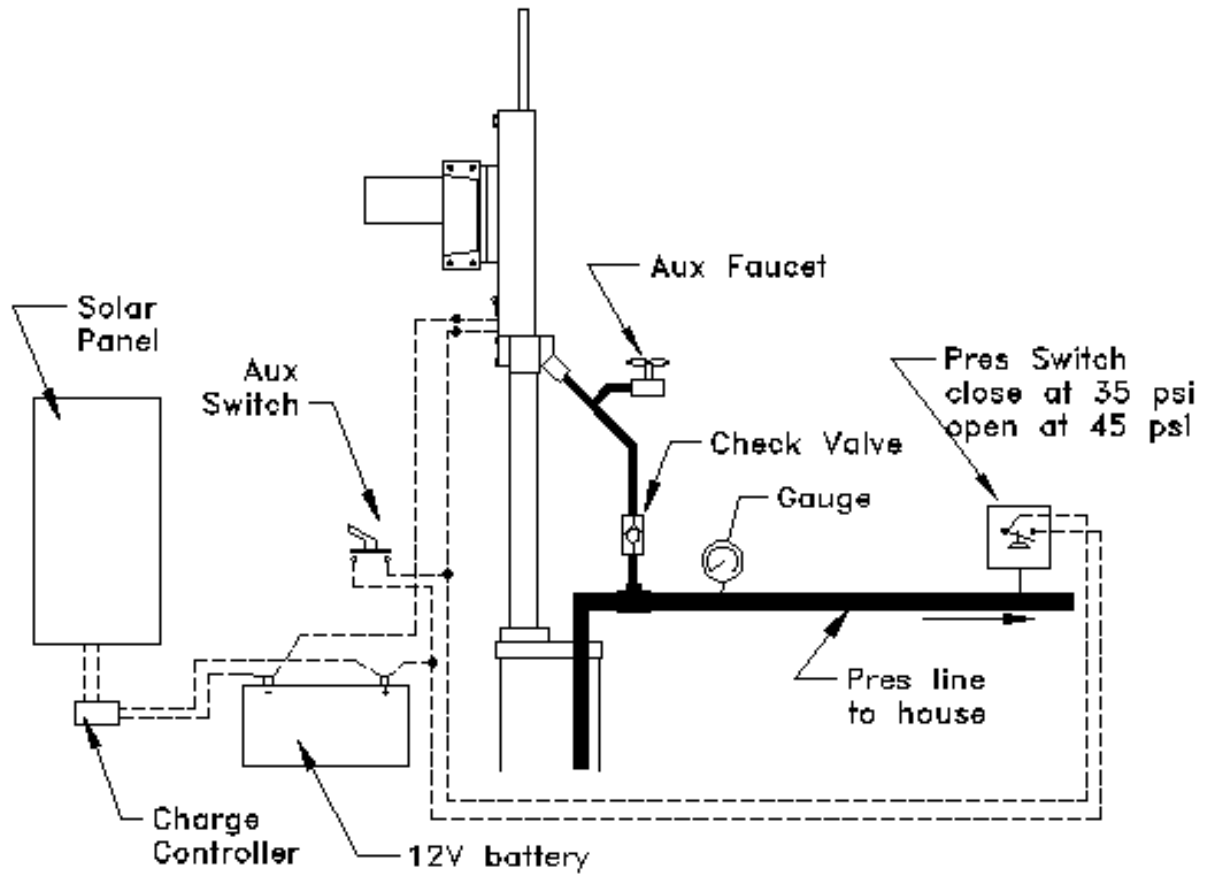

12V Gearmotor piping/wiring schematic

APPENDIX F

Example of how to freeze-proof a home-tied pressurized system with the pump.

**This is just one example to assist you with your planning.
We can assist you if you have questions about your particular situation.**

Hand or motorized pressure-pumping with frost protection in sub-freezing climates

Pump Head
(shown without motor or
hand lever attached)

Put optional pressure gauge (for hand or motor pumping)
or pressure switch (for motor pumping) here.

See details below

Put "T" for outside faucet and a gate valve in the line here
if you also want to be able to get water at the pump head.

This method is adaptable to non-pitless systems also.

Bleeder #2 is a brass ball-type bleeder

Grade

Removable lid

Bleeder #2 drains water - prevents freeze-up.

Check-valve

Coupling

Well Casing

Pitless Adapter

Crushed stone and soil drain method or use the drain
hole in the box if your terrain slopes away from the box

To
House

Pre-drilled bleeder hole #1 relieves pressure which opens bleeder #2
so the entire pump assembly and water line is frost-proofed.